

1:12 SCALE ELECTRIC SUSPENSION RACING CAR

TURBO

SPECIAL FEATURES

- * INDEPENDENT ADJUSTABLE SWING-ARM SUSPENSION.
- * ADJUSTABLE FRONT ANTI-ROLL BAR
- * SINGLE REAR ADJUSTABLE OIL/SPRING ABSORBER.
- * 3.3 MM THICKNESS POLYCARBONATE CHASSIS.
- * ADJUSTABLE BALL-RACE TYPE DIFFERENTIAL UNIT.
- * EXTRA LIGHT-WEIGHT WHEELS.
- * MOLDED FRONT & REAR TIRES.
- * SUPER-LIGHT RESISTOR & WIPER.
- * UNIVERSAL SERVO MOUNT BRACKET.
- * COUNTER SINK SCREWS.
- * ADJUSTABLE FRONT BODY POST.
- * ADJUSTABLE REAR BODY POST.
- * ATTRACTIVE LOW PRICE.



Adjustable front swing arm suspension system can be adapted to other 1/12 racing cars to improve handling.

- * Single rear adjustable absorber
- * Lightened 3mm lexan chassis



MANUFACTURED BY



TURBO

Systems

INTRODUCTION

Welcome to the exciting world of radio controlled racing car. We thank you for buying our car and we hope that you get satisfaction and fun from it.

Our car had gone through a full year of race track proven research and development rather than copying an exist model.

The TURBO - U car features the lightened 3 mm thickness of polycarbonate chassis with single rear adjustable hydraulic shock absorber to suit most racing conditions. Thanks to the swinging arm type front independent suspension, the static tweak of the chassis is almost non-existing in our car. The standard weight of our car with two mini servos is just a few grams over the minimum weight (879 grams) required for racing, thus you do not have to spend money in buying the lightweight screws and super light axle.

To insure maximum performance from your car we recommend that you read and follow the assembly instructions carefully.



TOOLS REQUIRED FOR COMPLETING THE CAR

3/16 " slot screw driver
8" Vice-grip plier
40 watts solding iron and 60/40 rosin core solder
X-acto knife or cutter
Contact cement
1/8" size allen key
Light grade machine oil
Needle nose plier

***** CAUTIONS *****

- ! DO NOT OVERCHARGE BATTERIES
- ! DO NOT SHORT CIRCUIT THE BATTERIES THAT CAN CAUSE BURNS OR FIRE
- ! DO NOT REVERSE-CHARGE THE BATTERIES OR PERMANENT DAMAGE MAY RESULT
- ! DO NOT RUN THE CAR AROUND WATER OR ON WET SURFACE
- ! DO NOT APPLY POWER WHEN THE CAR HIT BARRIER AND STOP
- ! DO NOT RUN THE CAR ON PUBLIC ROAD
- ! GEAR ON R/C CAR CAN CAUSE CUTS OR ENTANGLE HAIR, KEEP HANDS AND HAIRS AWAY FROM GEARS.
- ! THE CAR AND BODY HAVE SOME SHARP EDGES THAT CAN CAUSE CUT
- ! THE ROLL-OVER ANTENNA CAN CAUSE EYE INJURY IF NOT HANDLED PROPERLY
- ! NEVER CLEAN THE CAR WITH PETROLIUM THAT CAN START FIRE AND BAD BURNS TO YOUR BODY WHEN THE BATTERIES IS SHORT-CIRCUITED ACCIDENTIALLY
- ! DO NOT CLEAR THE POLYCARBONATE CHASSIS WITH GASOLINE, NITRO METHANE AND AMMONIA, BUT ONLY WITH WOOD ALCOHOL

FRONT SUSPENSION CONSTRUCTION

CONTENTS:

- Short stub axle x4
- Long stub axle x2 (for front axles)
- E-clips x8
- Steering block x2
- Spring x2
- Suspension strut x2
- Upper suspension pivot pin (small) x2
- Lower suspension pivot pin (large) x2
- Upper suspension bracket (U-shape) x2
- lower suspension bracket (L-shape) x2
- Left suspension arm (marked 0) x1
- Right suspension arm (marked 1) x1



STEPS:

- 1) Install front axles to the steering block then secures by E-clips
- 2) Insert kingpins through suspension arms so that the steering arms are facing to the side marked either '0' or '1' on the suspension arms, then secured with E-clips. (see photo A)

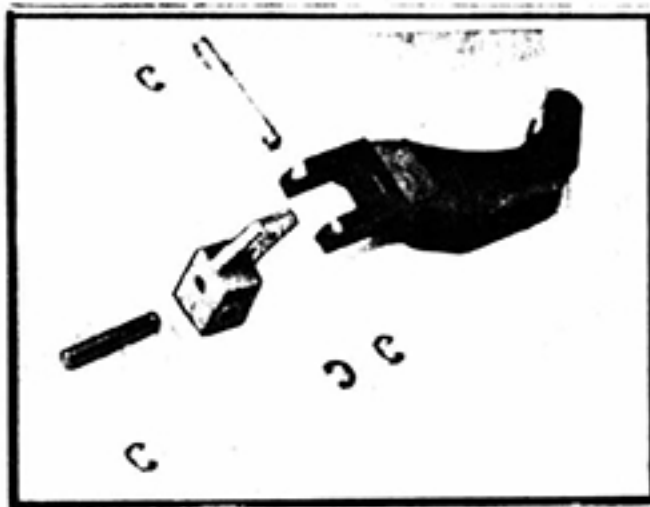

- 3) Install the suspension struts before pressing the upper pivot pins through suspension brackets and central block (see photo B)

- 4) Press with the vice-grip plier, locate the lower pivot pin through the holes of the suspension arm with the lower bracket in the middle, then coil the spring for about 2.5 mm to obtain the medium spring rate setting to start with. (see photo C).
- 5) Insert the strut through the coil-spring and mounting bracket (see photo D).

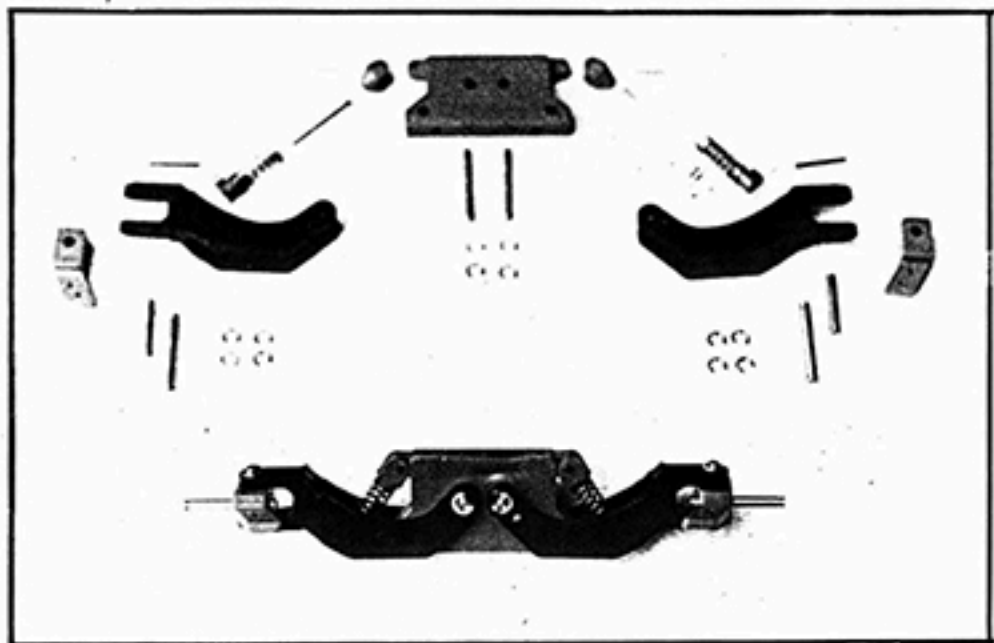
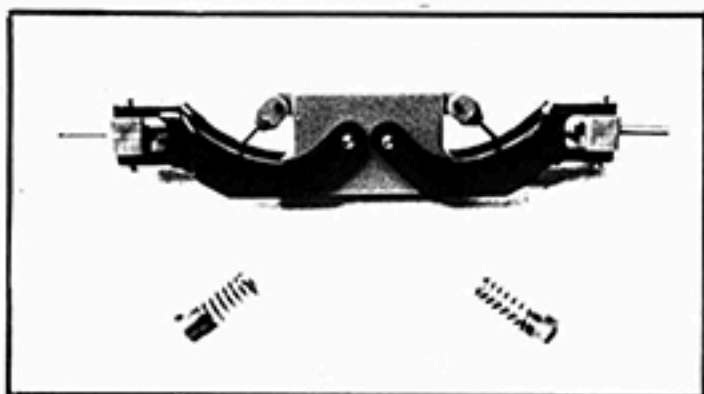
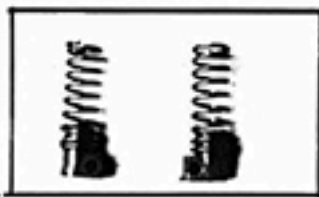

TIE-ROD & SERVO SAVER

CONTENTS:

Z-END STEEL RODS X4

ROD CONNECTOR X2

SERVO SAVER (4 m.m. SQUARE DRIVE FITS FOR BATAM MIDGET & FUTABA S-2

.....

Mount the servo in the position that the servo drive shaft is aligned to the centreline of the front block for the best steering operations. (see photo E).

When using servos with pinion drive shaft, a simple yet effective method can be applied. (see photo F).

The servo saver supplied can be trimmed-adjust for hardness. (see photo G).

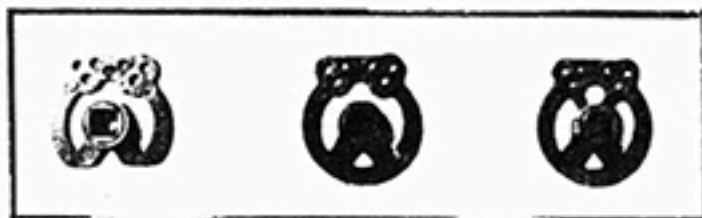
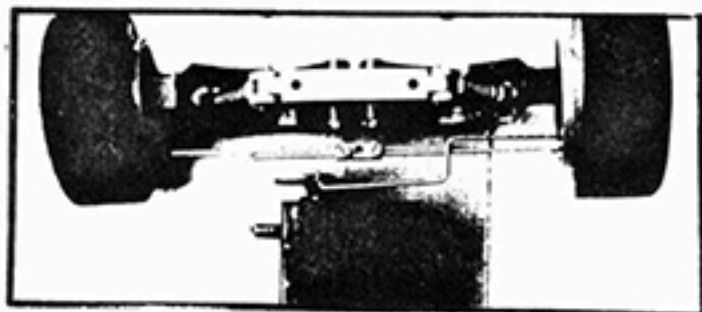
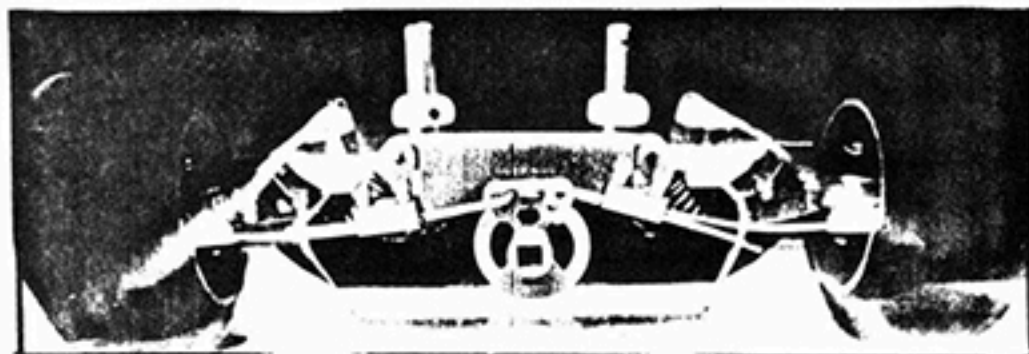

GENERAL HINTS FOR TUNING THE FRONT SUSPENSION UNIT

SPRING RATE ADJUSTMENT.

The spring supplied is a tight-fit to the lower mounting bracket that can be coiled up and down for about 4 m.m. for ride-height and the hardness of the suspension. Softer spring decreases understeering and lower front ride height. It is recommended to start from the mid-point.

CASTOR ANGLE.

The suspension arms has been set at 7 degrees positive castor angle for the best result of stability and throttle-induced steering effort on general track surfaces. Should one intends to modify the castor angle to suits his own drive tactic, sand the underside of the central block to the desired angle \pm 7 degrees.

TOE-IN.

Zero degree for toe-in for most of the Can-Am/GTP bodies and about 5 degrees for saloon/ or Formula bodies.

STEERING ANGLE ADJUSTMENT.

The nearer holes to the front axles on the steering blocks for connecting tie-rods offer faster response and greater steering angles, thus work best on high traction track. The farther holes connection work better on slippery ground. Always install the servo saver with the connecting points on top even difficult works in reversing the servo direction either by rotating the steering stick base through 180° (channel 1 stick on normal two-channels transmitter) or consult your local hobby shop for modification to the servo with the non-reversible switch steering wheel type transmitter, because by doing that gives a bump steer toe-in phenomenon that stabilizes the car in cornering.

CHASSIS STATIC TWEAK.

The most effective way of adjusting 'tweaked chassis' is by altering the spring rate; for example, if the car understeers in righthand turn, but oversteers in other direction, the remedy is either harden the right side spring or soften the left side one that depends on the wearing shape of the front tires. More wearing on the outside rim indicates a softer load spring is needed on this side. Sometimes the misaligned holes in the car body for the body pin will also tweak the chassis.

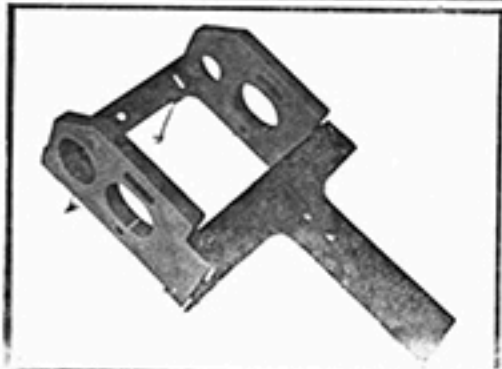
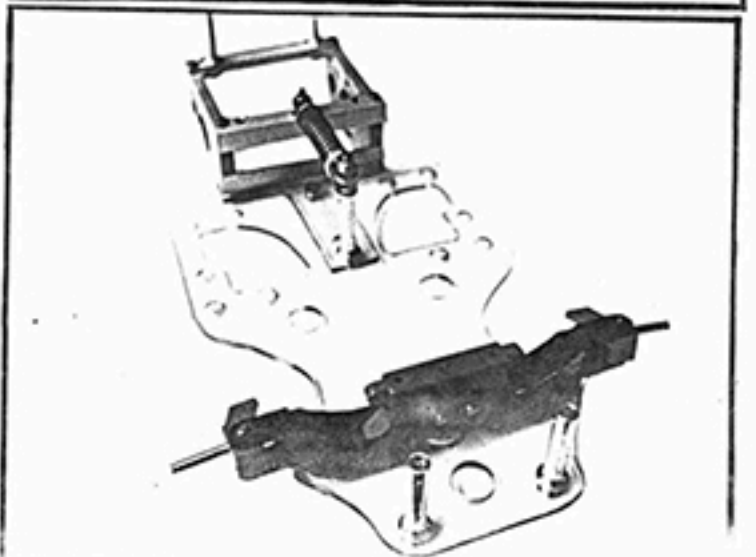
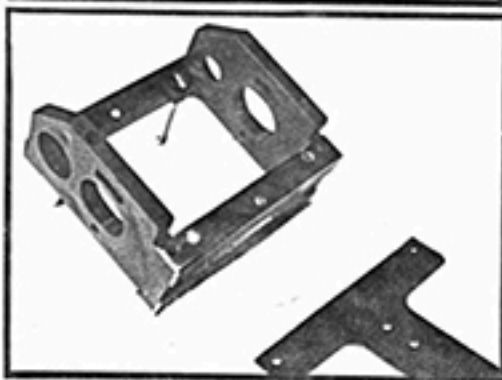
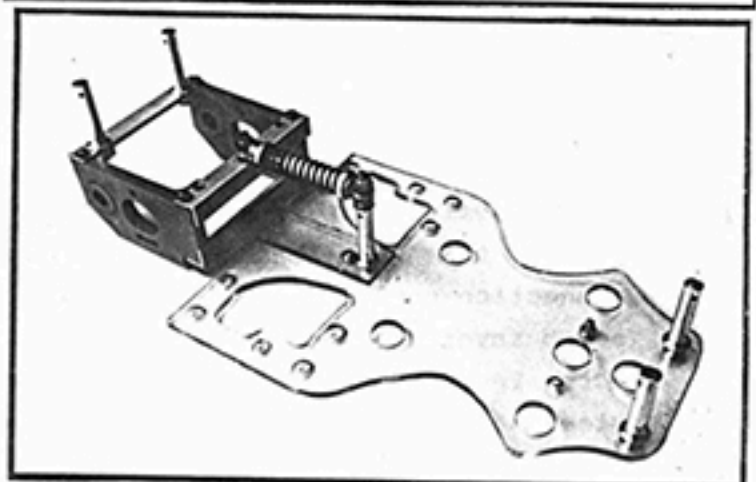
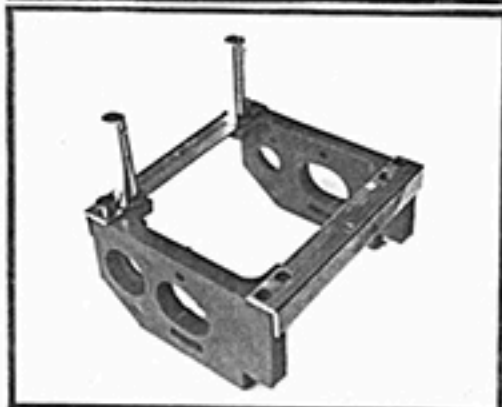
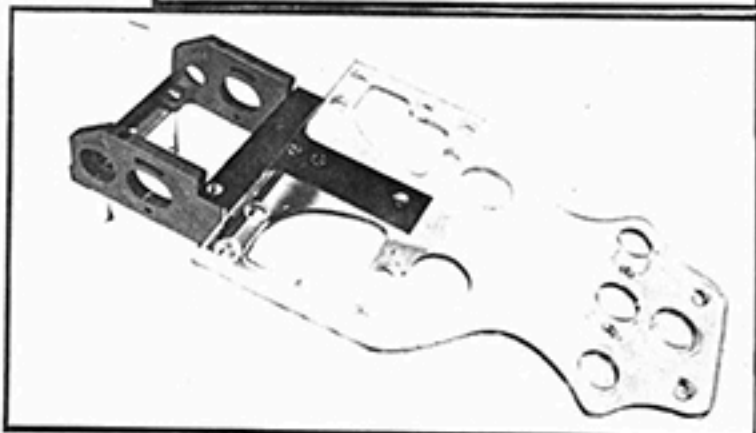
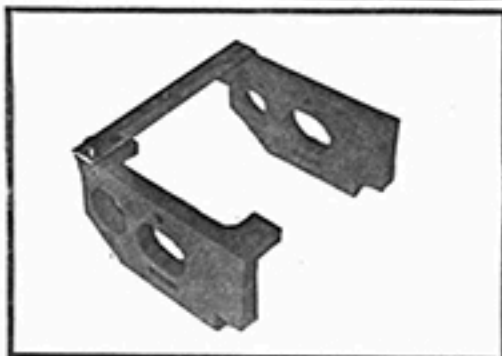
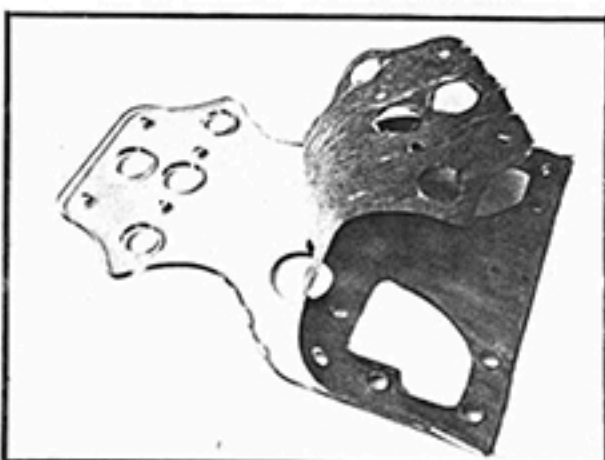
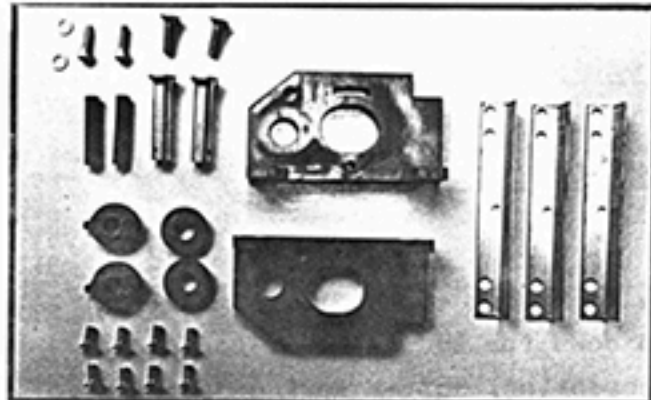

DIFFERENTIAL GEAR AXLE.

CONTENTS:

- Spur gear x1
- Axle shaft x1
- Thrust bearing washer x4
- Steel ball x10
- Thrust bearing x1
- Locknut x1
- Spring washer x1

.....

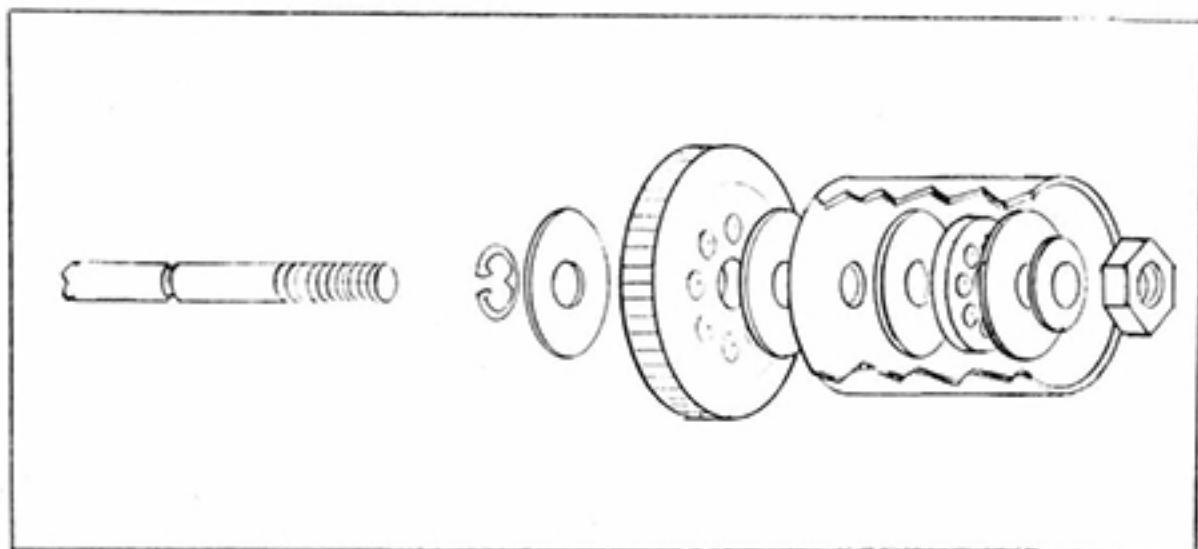

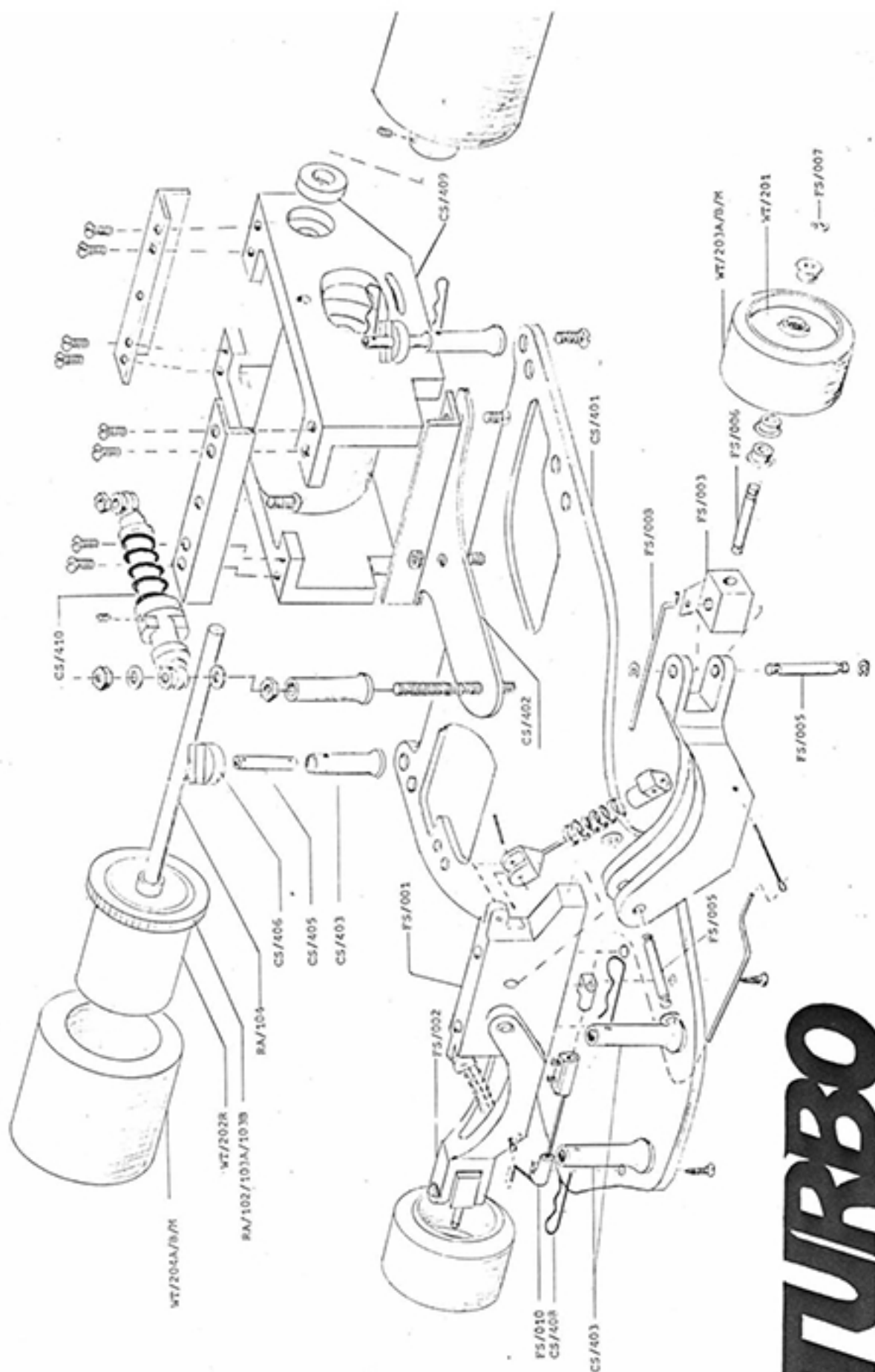

TURBO

NICKEL CADMIUM (NICAD) BATTERY

The rechargeable Nickel -cadmium battery is used for running the car. It is rated at 1200 maH and 1.2 volt each cell. They can discharge 1 amp. of electric current for one hour and twelve minutes or 8 amp. for 9 minutes, that is about the consumption of a standard 05 type motor on a 1/12 scale electric car. The running time varies on the factors such as the weight of the car, the air drag of the body, overall gearing, and the surface and layout of the track.

As a Nicad is being charged, the current that passes through the cell causes a chemical conversion to take place and, in this way, energy is stored. But, due to the limited capacity of batteries, eventually no more chemical conversion can take place and this energy going to the cell and is giving off as heat and pressure build up that eventually release through the pressure relief valve with some electrolyte that reduce the charging capacity of the battery.

The battery that gives higher discharge rate and also take higher charging voltage and current. Gerentially, 3 - 5 amps charging is recommended either by a simple charge cord from a 12 volt car battery or a AC to DC transformer of 0 - 12 volts range with adjustable current and a 0 - 10 Ammeter. If the charging current is known as 4 amp. the charging time is about 16 to 20 minutes depending on the condition of each pack of battery. Discontinue the charging once the cells are getting warm.

Another popular charging method of getting a fully-charged nicad is by Voltage indication of a digital voltmeter connecting to the terminals of nicad in parallel during charging. The reading is climbing up to a point that begins to fall and the charging is stopped immediately.

After several fast charges cycles, the cells should be equalized by slow charge at around 50 - 100 ma. for overnight.

The about procedures should fulfill most of the weekend hobbyist. As for serious racers who want to have the utmost performance from their battery should take advice from the experiance racers and analyse the casue by self-experiment.

USES OF ALUMINIUM STANDS AND NYLON TUBES

(A) As front body stands for low profile body :

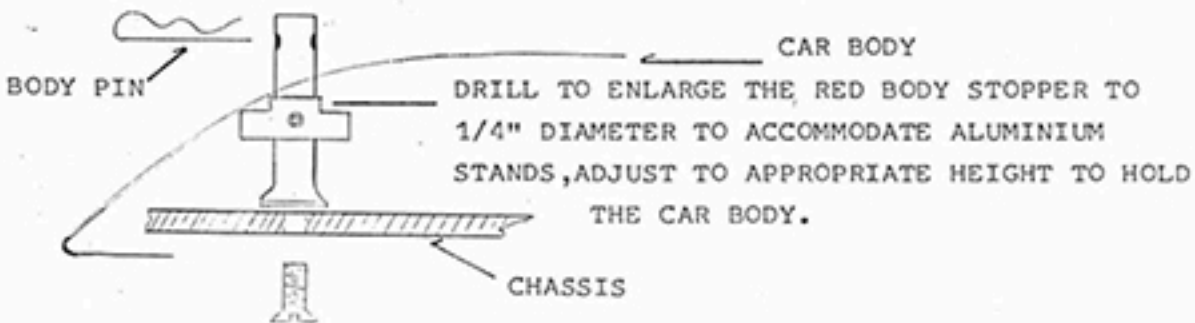

(B) As front body stands for tall body and Rear body mount/wing tubes:

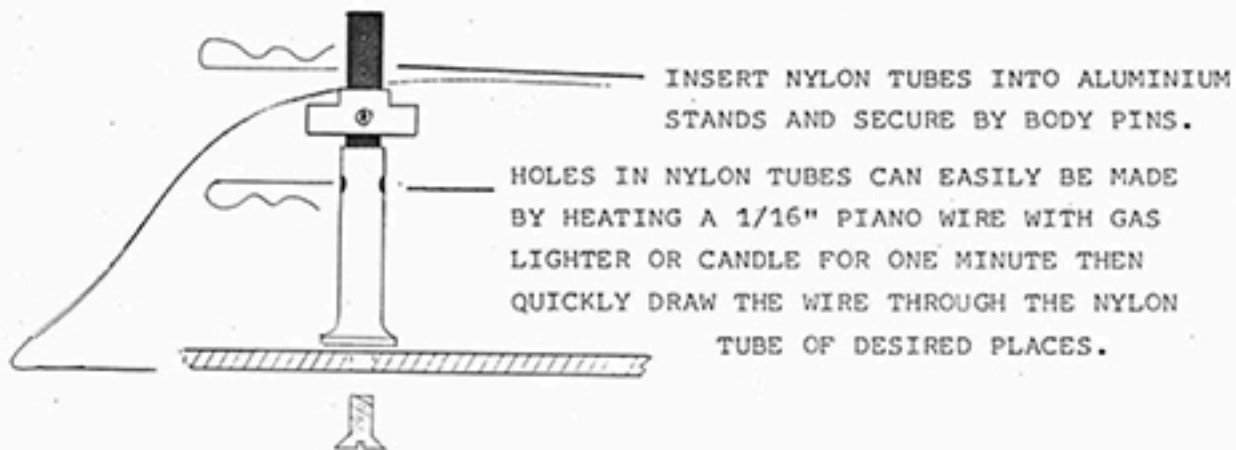

.....

MOTOR CARE AND TUNING FOR SPEED

Motor used for 1/12 scale racing car is classified as 05 that is equivalent to the power output of a glowplug internal combustion engine of 0.049 cu. inches capacity tested with different sizes of propellers on the test bench few years ago. They operate on 5 to 8 volts direct current (DC) with unloaded speed of 16000 to 28000 rpm depending on the number of turns of wiring on the armatures, the thickness of the wire and voltage available and draw as much as 25 to 30 amps. during stall and acceleration.

The motor is designed to run anti-clockwise direction when seen from the shalf side of the can. Always mount the motor that the pinion is on the righthand side of the car seen from the tail. If you find the car is running backward, simply reverse the leads of the motor.

Motors, when used for racing, need careful run-in period of 8 hours at 1.5 volts to have the brushed seated and bearing aligned. Slightly apply light machine oil to the bearings before run-in and take notice that not getting into the commutator. Extra punch in acceleration is expected after run-in.

Never disassemble the back plate of the motor for any reason except replacing of the brushes together with the back plate after a long time of operation. The offset aligned brushes need to go through another run-in to give good performance.

For the same reason, a change of gear ratio is preferable to altering the static timing of the motor. a carefully selected gearing by running on the track against the clock gives the greatest cut in lap time than anything else.

ALIGN THE SERVO DRIVE
SHALF TO THE CENTERLINE
OF THE FRONT BLOCK.
USE DOUBLE SIDE TAP.

'SURE GRIP' CONNECTOR
FOR ADJUSTING TOE-IN ANGLE

CHANNEL I
SERVO

RESISTOR

WIPER

CHANNEL II
SERVO

RECEIVER
USE DOUBLE SIDE
TAP TO SECURE

6 CELLS

NI.CAD.

NYLON
STRIPE
USE 2mm
DOUBLE-SIDE
TAP UNDERNEATH
THE NICAD STICKS

REAR BLOCK

POSITIONING OF R/C SET AND NI-CAD. BATTERY

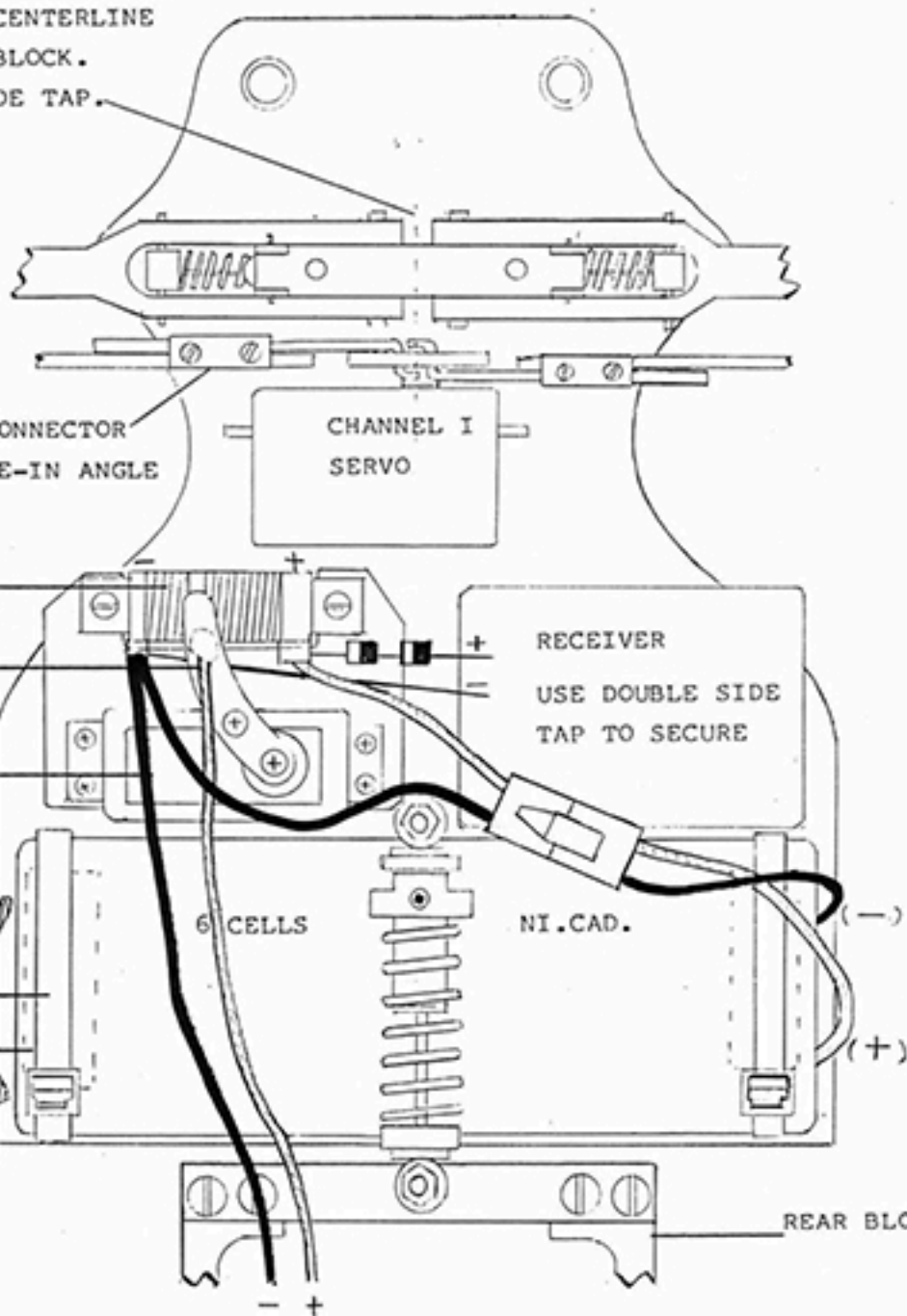

CAR BODY PAINTING AND TRIMMING

Before painting, place the body over your car and position it by centering the wheels in the wheel wells. While looking straight down on the body mark the locations of the front body mounts, the wing mounting tubes, and the antenna, with a marking pen. These marks will be used to locate mounting holes in the body after painting.

Consult your friendly hobby shop for suitable paint or spray available in your area. Some enamel and Vinyl upholstery paint are good for painting clear car body. Always practice painting on the wheel wells or back paneling to be cut out.

Use a very sharp knife or scissors, or a small tipped soldering iron, follow the trim lines around the sides and cockpit area and clean up with a sanding block, file or a burr on a hand grinder. Make sure the mounting holes in the body do not restrict the flex of the car.

When paint dried out, apply sponsor decals of your choice to make a realistic appearance.

